



## SUBMITTAL DATA SHEET

### AHU Heat Pump System

Location: \_\_\_\_\_  
 Engineer: \_\_\_\_\_  
 Submitted to: \_\_\_\_\_  
 Submitted by: \_\_\_\_\_  
 Reference: \_\_\_\_\_

Approval: \_\_\_\_\_  
 Date: \_\_\_\_\_  
 Construction: \_\_\_\_\_  
 Unit #: \_\_\_\_\_  
 Drawing #: \_\_\_\_\_

<b>Set Model</b>		CCOXHAAHU24 CCOXHASZ24HP	
<b>Certified</b>	AHRI		
	UL		



### SYSTEM PERFORMANCE DATA

<b>Power supply</b>		
Normal Operational Voltage	(V, Ph, Hz)	208/230V, 1Ph, 60Hz
Voltage Range	(V)	187-253
<b>Electrical</b>		
Minimum circuit ampacity(Outdoor)	(A)	25.0
Max.fuse(Outdoor)	(A)	35.0
Connection wiring		14AWG*4
<b>Cooling</b>		
Capacity	(Btu/h)	23000(7500~26000)
Power Input	(W)	1965(280~2600)
Current	(A)	8.7(2.4~11.5)
SEER2	(Btu/W)	18.4
EER2	(Btu/W)	11.7
<b>Heating</b>		
Capacity	(Btu/h)	26000(5600~29000)
Power Input	(W)	2180(350~2600)
Current	(A)	9.7(2.7~12)
HSPF2-4	(Btu/W)	9.3
HSPF2-5	(Btu/W)	7.5
COP	W/W	3.50
Heat at 17F(H32)	(Btu/h)	16900
Heat at 5F(H42)	(Btu/h)	21200
COP at 5F(H42)	W/W	1.90

### REFRIGERANT PIPE DATA

Throttle type	Indoor unit	N/A
	Outdoor unit	EXV+Throttle valve
Design pressure	(PSIG)	550/340
Refrigerant Type		R410A
Refrigerant charge	oz	91.71
Refrigerant precharge	(ft)	25.0
	(m)	7.5
Additional charge for each ft	(oz/ft)	0.32
Liquid side/ Gas side(indoor)	(inch)	3/8"/5/8"
Liquid side/ Gas side(outdoor)	(inch)	3/8"/5/8"
Max. pipe length	(ft)	98.4
Max. difference in level	(ft)	65.6
Connection method		Flared
Indoor(cooling)	(Deg. °F)	60~90
Indoor(heating)	(Deg. °F)	32~86
Outdoor(cooling)	(Deg. °F)	-22~122
Outdoor(heating)	(Deg. °F)	-22~75

### INDOOR UNIT DATA

<b>Indoor fan motor</b>		
Model		ZKFD-250-8-1
Qty		1
Input	(W)	/
Output	(W)	/
RLA	(A)	3.0
Speed(Hi/Mi/Lo)	(r/min)	/
<b>Air flow &amp; Noise level</b>		
Indoor air flow (Hi/Med/Lo) (No duct)	(CFM)	823.53/758.82/694.12/629.41
Indoor noise level (Hi/Med/Lo)	[dB(A)]	41/39/38
<b>Dehumidification</b>		
Indoor unit	(L/H)	1.98
<b>Indoor unit</b>		
Dimension (WxDxH)	(inch)	21.02x17.52x45.00
Packing(WxDxH)	(inch)	26.57x20.87x48.62
Net/Gross weight	(lbs.)	106.70/127.21

### OUTDOOR UNIT DATA

<b>Compressor</b>		
Type		Twin-ROTARY
Model		KTM240D43UKT
Brand		GMCC
Capacity	(Btu/h)	25931
Input	(W)	2045
Rated current (RLA)	(A)	17.1
Refrigerant oil/oil charge	(ml)	ESTER OIL VG74 620
<b>Outdoor fan motor</b>		
Model		ZKFN-120-8-2
Qty		1
Input	(W)	150.0
Output	(W)	120
RLA	(A)	0.5
Speed	(r/min)	950/800/500
<b>Air flow &amp; Noise level</b>		
Outdoor air flow (Max.)	(CFM)	2235
Outdoor noise level	[dB(A)]	62.0
<b>Outdoor unit</b>		
Dimension (WxDxH)	(inch)	37.24x16.14x31.89
Packing (WxDxH)	(inch)	42.91x19.69x34.84
Net/ Gross weight	(lbs.)	134.48/144.40

Indoor unit dimension

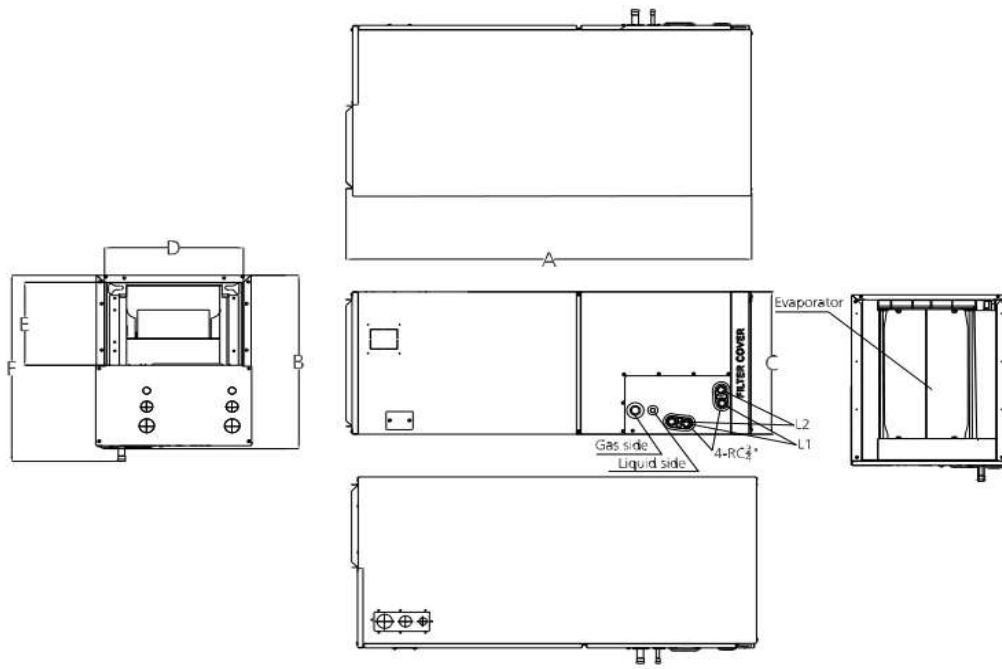

Model	Unit	Dimensions(mm)						Drain hole	
		A	B	C	D	E	F	L1	L2
18k~24k	mm	1143	534	445	400	260	585	Main drain	Overflow drain
	inch	45	21	17-1/2	15-3/4	10-1/4	23		
30k-48k	mm	1245	534	534	490	260	585		
	inch	49	21	21	19-5/16	10-1/4	23		
60k	mm	1346	534	622	580	260	585		
	inch	53	21	24-1/2	22-7/8	10-1/4	23		

Outdoor unit dimension

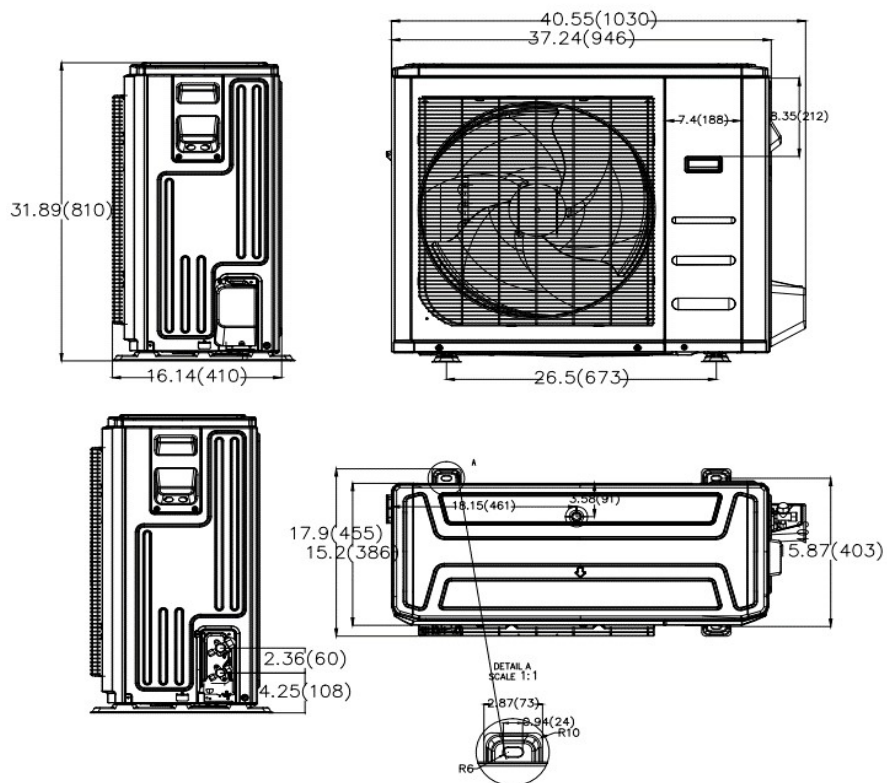

Fan performance

