



SUBMITTAL DATA SHEET

One Way Cassette Heat Pump System

Location: _____
 Engineer: _____
 Submitted to: _____
 Submitted by: _____
 Reference: _____

Approval: _____
 Date: _____
 Construction: _____
 Unit #: _____
 Drawing #: _____

Set Model
 Indoor unit model CCOXHA4C24
 Outdoor unit model CCOXHASZ24HP

Certified

AHRI  
 UL 



SYSTEM PERFORMANCE DATA

Power supply		
Normal Operational Voltage	(V, Ph, Hz)	208/230V, 1Ph, 60Hz
Voltage Range	(V)	187-253
Electrical		
Minimum circuit ampacity(Outdoor)	(A)	25.0
Max.fuse(Outdoor)	(A)	35.0
Connection wiring		14*4 AWG
Cooling		
Capacity	(Btu/h)	24000(8000~25000)
Power Input	(W)	2182(330~1560)
Current	(A)	8.5(2.6~11)
SEER2	(Btu/W)	20.5
EER2	(Btu/W)	11.0
Heating		
Capacity	(Btu/h)	25000(11800~27000)
Power Input	(W)	2093(685~2814)
Current	(A)	9.8(4.4~12.8)
HSPF2-4	(Btu/W)	11.5
HSPF2-5	(Btu/W)	9.2
COP	W/W	3.50
Heat at 17F(H32)	(Btu/h)	21000
Heat at 5F(H42)	(Btu/h)	25800
COP at 5F(H42)	W/W	2.00

REFRIGERANT PIPE DATA

Throttle type	Indoor unit	N/A
	Outdoor unit	EXV+Throttle valve
Design pressure	(PSIG)	550/340
Refrigerant Type		R410A
Refrigerant charge	oz	91.71
Refrigerant precharge	(ft)	25.0
Additional charge for each ft	(oz/ft)	0.32
Additional charge for each m	(g/m)	30.0
Liquid side/ Gas side(indoor)	(inch)	3/8" / 5/8"
Liquid side/ Gas side(outdoor)	(inch)	3/8" / 5/8"
Max. pipe length	(ft)	164.0
Max. difference in level	(ft)	82.0
Connection method		Flared
Indoor(cooling)	(Deg. °F)	60~90
Indoor(heating)	(Deg. °F)	32~86
Outdoor(cooling)	(Deg. °F)	-22~122
Outdoor(heating)	(Deg. °F)	-22~75

INDOOR UNIT DATA

Indoor fan motor		
Model		ZKFN-45-8-1
Qty		1
Input	(W)	/
Output	(W)	45.0
RLA	(A)	1.00
Speed(Hi/Mi/Lo)	(r/min)	680/624/568/512
Air flow & Noise level		
Indoor air flow (Hi/Med/Lo) (No duct)	(CFM)	764.71/705.88/635.29/547.06
Indoor noise level (Hi/Med/Lo)	[dB(A)]	48/45.5/43
Dehumidification		
	(L/H)	2.72
Indoor unit		
Dimension (WxDxH)	(inch)	32.68x32.68x8.07
Packing(WxDxH)	(inch)	35.83x35.83x9.84
Net/Gross weight	(lbs.)	47.18/55.34

OUTDOOR UNIT DATA

Compressor		
Type		Twin-ROTARY
Model		KTM240D43UKT
Brand		GMCC
Capacity	(Btu/h)	25931
Input	(W)	2045
Rated current (RLA)	(A)	17.1
Refrigerant oil/oil charge	(ml)	ESTER OIL VG74 620
Outdoor fan motor		
Model		ZKFN-120-8-2
Qty		1
Input	(W)	150.00
Output	(W)	120.00
RLA	(A)	0.50
Speed	(r/min)	950/800/500
Air flow & Noise level		
Outdoor air flow (Max.)	(CFM)	2235.3
Outdoor noise level	[dB(A)]	62.0
Outdoor unit		
Dimension (WxDxH)	(inch)	37.24x16.14x31.89
Packing (WxDxH)	(inch)	42.91x19.69x34.84
Net/ Gross weight	(lbs.)	134.48/144.40

Indoor unit dimension

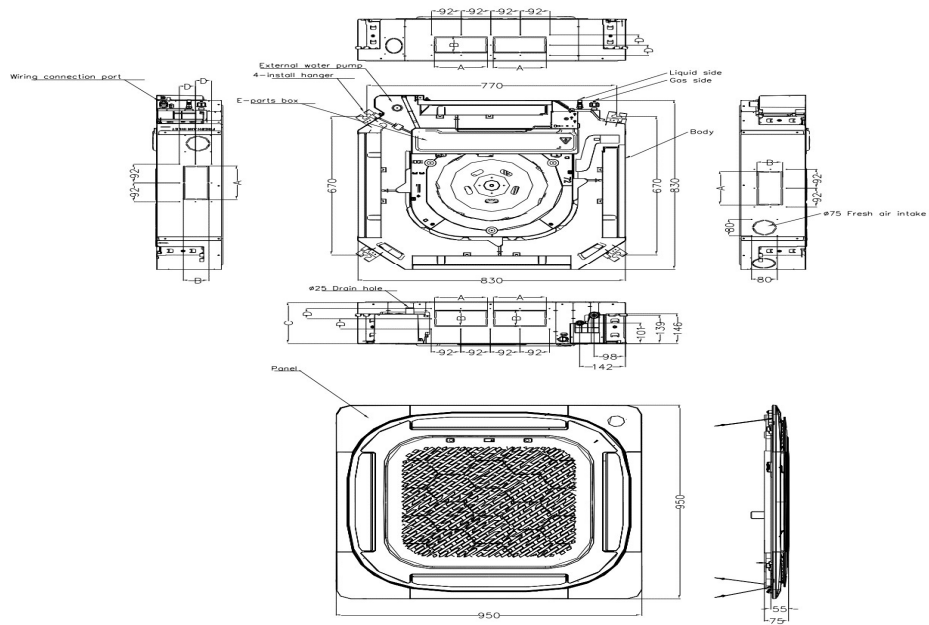

Capacity (Btu/h)	Unit	A	B	C	D
24K	mm	165	80	205	50
	inch	6.5	3.15	8.07	1.97
36K	mm	165	100	245	60
	inch	6.5	3.64	9.65	2.36
48K	mm	165	100	287	60
	inch	6.5	3.64	11.30	2.36

Outdoor unit dimension

