

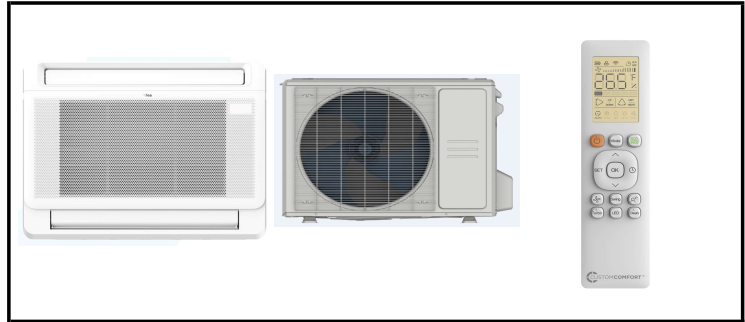

SUBMITTAL DATA SHEET

Console Heat Pump System	
Location: _____ Engineer: _____ Submitted to: _____ Submitted by: _____ Reference: _____	Approval: _____ Date: _____ Construction: _____ Unit #: _____ Drawing #: _____

Set Model	Indoor unit model CCOXHAFM18
	Outdoor unit model CCOXHASZ17HP
Certified	AHRI UL



SYSTEM PERFORMANCE DATA

Power supply		
Normal Operational Voltage	(V, Ph, Hz)	208/230V, 1Ph, 60Hz
Voltage Range	(V)	187-253
Electrical		
Minimum circuit ampacity(Outdoor)	(A)	20.0
Max.fuse(Outdoor)	(A)	25.0
Connection wiring		0
Cooling		
Capacity	(Btu/h)	16000(7800~16400)
Power Input	(W)	1456(340~1774)
Current	(A)	6.66(2.55~7.85)
SEER2	(Btu/W)	20.2
EER2	(Btu/W)	11.0
Heating		
Capacity	(Btu/h)	17000(8600~21800)
Power Input	(W)	1779(590~2063)
Current	(A)	8.0(3.95~9.05)
HSPF2-4	(Btu/W)	8.9
HSPF2-5	(Btu/W)	7.3
COP	W/W	2.80
Heat at 17F(H32)	(Btu/h)	14700
Heat at 5F(H42)	(Btu/h)	16700
COP at 5F(H42)	W/W	1.76

REFRIGERANT PIPE DATA

Design pressure	(PSIG)	550/340
Refrigerant Type		R410A
Refrigerant charge	oz	65.26
Refrigerant precharge	(ft)	0.0
Additional charge for each ft	(oz/ft)	0.16
Liquid side/ Gas side(indoor)	(inch)	1/4"/1/2"
Liquid side/ Gas side(outdoor)	(inch)	1/4"/1/2"
Max. pipe length	(ft)	98.4
Max. difference in level	(ft)	65.6
Connection method		Flared
Indoor(cooling)	(Deg. °F)	60~90
Indoor(heating)	(Deg. °F)	32~86
Outdoor(cooling)	(Deg. °F)	-22~122
Outdoor(heating)	(Deg. °F)	-22~75

INDOOR UNIT DATA

Indoor fan motor		
Model		ZKFP-13-8-136+ZKFP-13-8-104
Qty		1+1
Input	(W)	/
Output	(W)	13.0
RLA	(A)	1.03
Speed(Hi/Mi/Lo)	(r/min)	1100/1000/900
Air flow & Noise level		
Indoor air flow (Hi/Med/Lo) (No duct)	(CFM)	500.00/441.18/382.35/323.53
Indoor noise level (Hi/Med/Lo)	[dB(A)]	45/40.5/30
Dehumidification		
	(L/H)	2.05
Indoor unit		
Dimension (WxDxH)	(inch)	31.26x7.87x24.45
Packing(WxDxH)	(inch)	34.06x11.02x28.31
Net/Gross weight	(lbs.)	32.85/41.45

OUTDOOR UNIT DATA

Compressor		
Type		Twin-ROTARY
Model		KTM240D43UKT
Brand		GMCC
Capacity	(Btu/h)	25931
Input	(W)	2045
Rated current (RLA)	(A)	14.3
Refrigerant oil/oil charge	(ml)	ESTER OIL VG74 620
Outdoor fan motor		
Model		ZKFN-80-8-3
Qty		1
Input	(W)	/
Output	(W)	80.00
RLA	(A)	0.76
Speed	(r/min)	810/720
Air flow & Noise level		
Outdoor air flow (Max.)	(CFM)	1764.7
Outdoor noise level	[dB(A)]	58.0
Outdoor unit		
Dimension (WxDxH)	(inch)	35.04x13.46x26.50
Packing (WxDxH)	(inch)	39.17x15.67x29.13
Net/ Gross weight	(lbs.)	100.97/108.03

Indoor unit dimensions

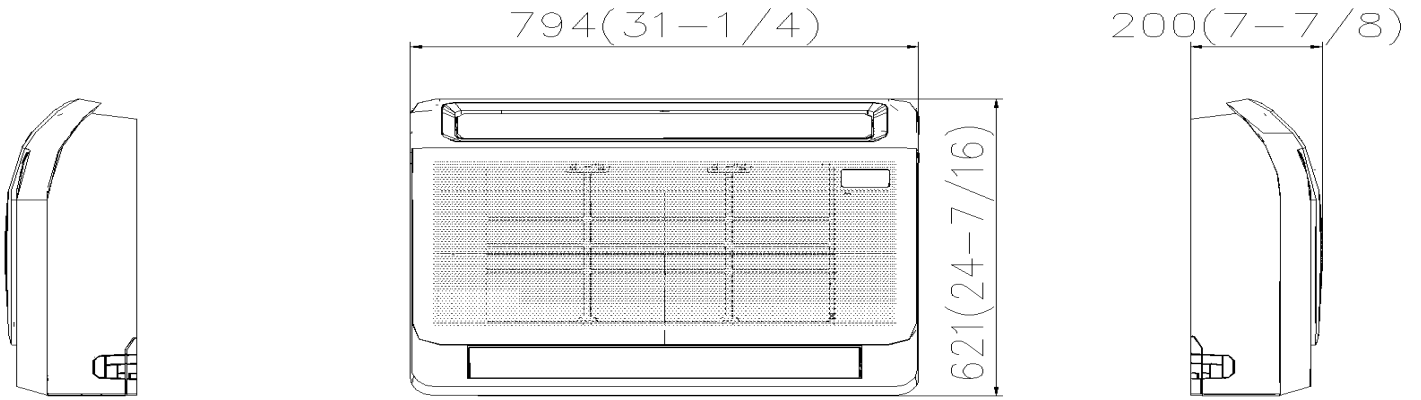

Outdoor unit dimensions

