



SUBMITTAL DATA SHEET

One Way Cassette Heat Pump System

Location: _____
 Engineer: _____
 Submitted to: _____
 Submitted by: _____
 Reference: _____

Approval: _____
 Date: _____
 Construction: _____
 Unit #: _____
 Drawing #: _____

Set Model		
Indoor unit model	CCOXHA1C12	
Outdoor unit model	CCOXHASZ12HP	
Certified	AHRI	
	UL	
		

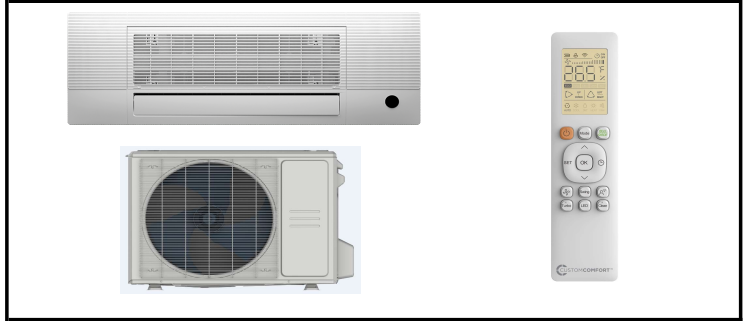

SYSTEM PERFORMANCE DATA

Power supply		
Normal Operational Voltage	(V, Ph, Hz)	208/230V, 1Ph, 60Hz
Voltage Range	(V)	187-253

Electrical		
Minimum circuit ampacity(Outdoor)	(A)	15.0
Max.fuse(Outdoor)	(A)	15.0
Connection wiring		14*4 AWG

Cooling		
Capacity	(Btu/h)	12000(4000~14100)
Power Input	(W)	923(147~1257)
Current	(A)	4.17(1.17~5.54)
SEER2	(Btu/W)	23.0
EER2	(Btu/W)	13.0

Heating		
Capacity	(Btu/h)	12500(4600~15000)
Power Input	(W)	1150(362~1500)
Current	(A)	4.85(1.73~6.59)
HSPF2-4	(Btu/W)	10.0
HSPF2-5	(Btu/W)	7.8
COP	W/W	3.19
Heat at 17F(H32)	(Btu/h)	9500
Heat at 5F(H42)	(Btu/h)	11000
COP at 5F(H42)	W/W	1.80

REFRIGERANT PIPE DATA

Design pressure	(PSIG)	550/340
Refrigerant Type		R410A
Refrigerant charge	oz	41.62
Refrigerant precharge	(ft)	25.0
Additional charge for each ft	(oz/ft)	0.16
Liquid side/ Gas side(indoor)	(inch)	1/4" / 1/2"
Liquid side/ Gas side(outdoor)	(inch)	1/4" / 1/2"
Max. pipe length	(ft)	82.0
Max. difference in level	(ft)	32.8
Connection method		Flared

OPERATING RANGE

Indoor(cooling)	(Deg. °F)	60~90
Indoor(heating)	(Deg. °F)	32~86
Outdoor(cooling)	(Deg. °F)	-22~122
Outdoor(heating)	(Deg. °F)	-22~75

INDOOR UNIT DATA

Indoor fan motor		
Model		ZKFN-30-8-43
Qty		1
Input	(W)	/
Output	(W)	30.0
RLA	(A)	1.00
Speed(Hi/Mi/Lo)	(r/min)	1075/982/797

Air flow & Noise level		
Indoor air flow (Hi/Med/Lo) (No duct)	(CFM)	352.94/311.76/282.35/247.06
Indoor noise level (Hi/Med/Lo)	[dB(A)]	38.5/37/32.5

Dehumidification	(L/H)	1.45
Indoor unit		
Dimension (WxDxH)	(inch)	50.31x13.19x8.98
Packing(WxDxH)	(inch)	57.60x22.48x22.64
Net/Gross weight	(lbs.)	45.19/82.89

OUTDOOR UNIT DATA

Compressor		
Type		ROTARY
Model		KTN110D42UFZ
Brand		GMCC
Capacity	(Btu/h)	11823
Input	(W)	885
Rated current (RLA)	(A)	8.8
Refrigerant oil/oil charge	(ml)	VG74/350

Outdoor fan motor		
Model		ZKFN-34-10-1
Qty		1
Input	(W)	/
Output	(W)	34.00
RLA	(A)	0.36
Speed	(r/min)	850/680/450

Air flow & Noise level		
Outdoor air flow (Max.)	(CFM)	1323.5
Outdoor noise level	[dB(A)]	56.0

Outdoor unit		
Dimension (WxDxH)	(inch)	31.69x12.99x21.81
Packing (WxDxH)	(inch)	36.02x14.57x24.21
Net/ Gross weight	(lbs.)	73.63/79.37

Indoor unit dimensions

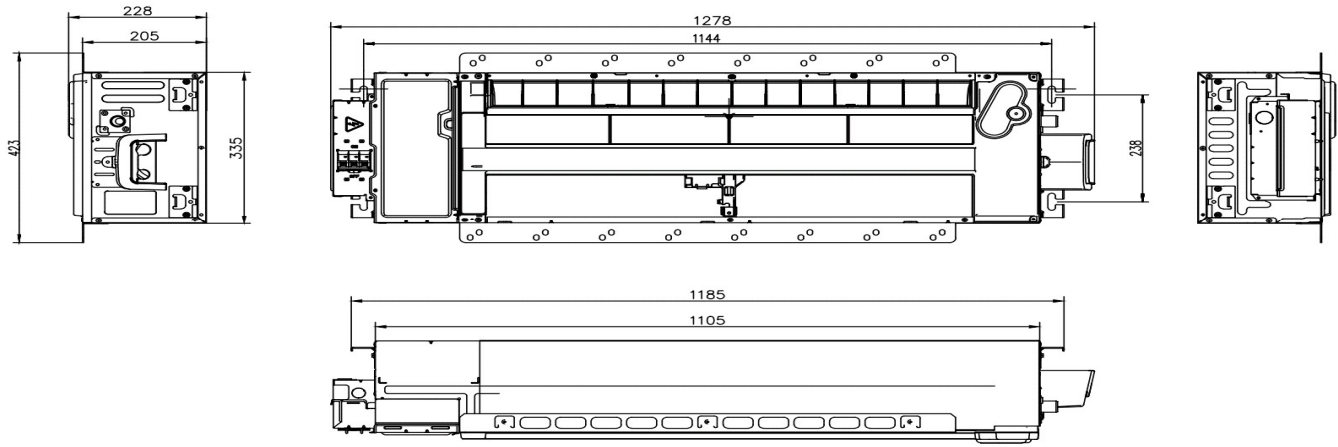

Outdoor unit dimensions

