



SUBMITTAL DATA SHEET

A-Coil Heat Pump System

Location: _____ Engineer: _____ Submitted to: _____ Submitted by: _____ Reference: _____	Approval: _____ Date: _____ Construction: _____ Unit #: _____ Drawing #: _____
--	--

Set Model	
Indoor unit model	CCOEHACC3036C
Outdoor unit model	CCOXHA24V30HP
Certified	
AHRI	
UL	

SYSTEM PERFORMANCE DATA

Power supply		
Normal Operational Voltage	(V, Ph, Hz)	208/230V, 1Ph, 60Hz
Voltage Range	(V)	187-253
Electrical		
Minimum circuit ampacity	(A)	23.0
Max.fuse	(A)	35.0
Connection wiring		18AWG
Cooling		
Rated Capacity	(Btu/h)	30000
Capacity Range	(Btu/h)	9900~35000
Power Input (Max)	(W)	2855(660~3720)
Rated current	(A)	11.1(3.10~14.4)
SEER	(Btu/W)	15.5
EER	(Btu/W)	10.5
Heating at 47F		
Rated Capacity	(Btu/h)	33000
Capacity Range	(Btu/h)	9000~37000
Power Input (Max)	(W)	2850(640~3300)
Rated current	(A)	11.0(3.00~13)
HSPF4	(Btu/W)	9.7
HSPF5	(Btu/W)	7.7
COP	W/W	3.39
Heating at 5F		
Capacity	(Btu/h)	27000
COP	W/W	1.85
REFRIGERANT PIPE DATA		
Design pressure	(PSIG)	550/340
Refrigerant Type	(Oz)	R410A/134.04
Refrigerant precharge	(ft)	25.0
Additional charge for each ft	(oz/ft)	0.69
Liquid side/ Gas side	(inch)	3/8" / 3/4"
Max. pipe length	(ft)	164.0
Max. difference in level	(ft)	82.0
Connection method	Indoor	Braze
	Outdoor	Flared to braze



INDOOR UNIT DATA

Throttle	TXV for Cooling	
Indoor unit		
Dimension (WxDxH)	(inch)	20.98x20.98x23.98
Packing(WxDxH)	(inch)	23.43x25.59x25.39
Net/Gross weight	(lbs.)	64.37/75.40

OUTDOOR UNIT DATA

Compressor		
Type		KTF310D43UMT
Model		ROTARY
Brand		GMCC
Capacity	(Btu/h)	34154.1
Input	(W)	2765
Rated current (RLA)	(A)	-
Refrigerant oil/oil charge	(ml)	VG74/1000
Throttle		
		EEV for heating
Outdoor fan motor		
Model		ZKFN-120-8-2
Qty		1
Input	(W)	-
RLA	(A)	1.35
Speed	(r/min)	950/900/500
Air flow & Noise level		
Outdoor air flow (Max.)	(CFM)	3000.0
Outdoor noise level	[dB(A)]	63.0
Outdoor unit		
Dimension (WxDxH)	(inch)	37.24x16.14x31.89
Packing (WxDxH)	(inch)	42.91x19.69x34.84
Net/ Gross weight	(lbs.)	159.83/169.75
Operating Range		
Indoor(cooling)	(Deg. °F / °C)	62~90 / 17~32
Indoor(heating)	(Deg. °F/ °C)	32~86 / 0~30
Outdoor(cooling)	(Deg. °F/ °C)	5~122 / -15~50
Outdoor(heating)	(Deg. °F/ °C)	-22~75 / -30~24

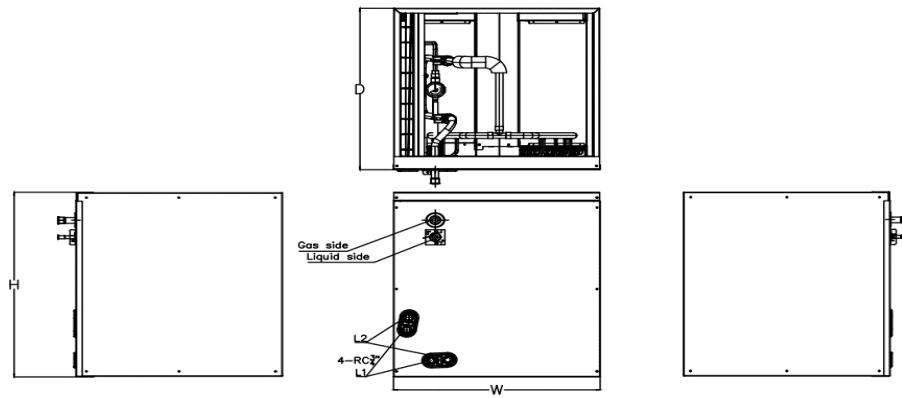
Indoor unit dimension



Model	Unit	Dimensions (mm)			Drain hole	
		W	D	H	L1	L2
12K-24K	mm	445	533	457	Main drain hole	Overflow drain hole
	inch	17 1/2	21	18		
30K-48K	mm	533	533	609		
	inch	21	21	24		
60K	mm	622	533	711		
	inch	24	21	28		

Outdoor unit dimension

