



SUBMITTAL DATA SHEET

AHU Heat Pump System

Location: _____
 Engineer: _____
 Submitted to: _____
 Submitted by: _____
 Reference: _____

Approval: _____
 Date: _____
 Construction: _____
 Unit #: _____
 Drawing #: _____

Set Model
 Indoor unit model CCOXHAH24V18
 Outdoor unit model CCOXHA24V18P

Certified

AHRI





ENERGY STAR

UL



LISTED



SYSTEM PERFORMANCE DATA

Power supply		
Normal Operational Voltage	(V, Ph, Hz)	208/230V, 1Ph, 60Hz
Voltage Range	(V)	187-253
Electrical		
Minimum circuit ampacity(Outdoor)	(A)	16.0
Max.fuse(Outdoor)	(A)	20.0
Connection wiring		14AWG*2 Stranded, shielded
Cooling		
Capacity	(Btu/h)	18000(6880~21000)
Power Input	(W)	1450(260~1890)
Current	(A)	6.4(1.5~8.3)
SEER2	(Btu/W)	18.0
EER2	(Btu/W)	12.4
Heating		
Capacity	(Btu/h)	19000(2800~21000)
Power Input	(W)	1530(430~1920)
Current	(A)	6.8(2.5~8.5)
HSPF2-4	(Btu/W)	9.3
HSPF2-5	(Btu/W)	7.6
COP	W/W	3.64
Heat at 17F(H32)	(Btu/h)	13500
Heat at 5F(H42)	(Btu/h)	16500
COP at 5F(H42)	W/W	2.04

REFRIGERANT PIPE DATA

Throttle type	Indoor unit	EEV for cooling
	Outdoor unit	EEV for heating
Design pressure	(PSIG)	550/340
Refrigerant Type		R410A
Refrigerant charge	oz	81.13
Refrigerant precharge	(ft)	25.0
Additional charge for each ft	(oz/ft)	0.69
Liquid side/ Gas side(indoor)	(inch)	3/8" / 3/4"
Liquid side/ Gas side(outdoor)	(inch)	3/8" / 5/8"
Max. pipe length	(ft)	98.4
Max. difference in level	(ft)	65.6
Connection method		Flared
Indoor(cooling)	(Deg. °F)	60~90
Indoor(heating)	(Deg. °F)	32~86
Outdoor(cooling)	(Deg. °F)	5~122
Outdoor(heating)	(Deg. °F)	-22~75

INDOOR UNIT DATA

Indoor fan motor		
Model		ZKFD-250-8-1
Qty		1
Input	(W)	/
Output	(W)	/
RLA	(A)	2.0
Speed(Hi/Mi/Lo)	(r/min)	/
Air flow & Noise level		
Indoor air flow (Hi/Med/Lo) (No duct)	(CFM)	617.65/576.47/529.41/488.24
Indoor noise level (Hi/Med/Lo)	[dB(A)]	34/31/30
Dehumidification	(L/H)	1.67
Indoor unit		
Dimension (WxDxH)	(inch)	21.02x17.52x45.00
Packing(WxDxH)	(inch)	26.57x20.87x48.62
Net/Gross weight	(lbs.)	105.82/129.41

OUTDOOR UNIT DATA

Compressor		
Type		Twin-ROTARY
Model		KTM240D57UMT
Brand		GMCC
Capacity	(Btu/h)	26409
Input	(W)	2085
Rated current (RLA)	(A)	10
Refrigerant oil/oil charge	(ml)	ESTER OIL VG74 670
Outdoor fan motor		
Model		ZKFN-80-8-3
Qty		1
Input	(W)	/
Output	(W)	80
RLA	(A)	1.0
Speed	(r/min)	800/700/580
Air flow & Noise level		
Outdoor air flow (Max.)	(CFM)	1279
Outdoor noise level	[dB(A)]	57.0
Outdoor unit		
Dimension (WxDxH)	(inch)	35.04x13.46x26.50
Packing (WxDxH)	(inch)	39.17x15.67x29.13
Net/ Gross weight	(lbs.)	102.95/109.79

Accessories

Adaptor for welding(3/4")	Qty	1 Indoor & 1 Outdoor
Adaptor for welding(3/8")	Qty	2 Indoor & 1 Outdoor
Adaptor (5/8" to 3/4")	Qty	1 Indoor

Indoor unit dimension

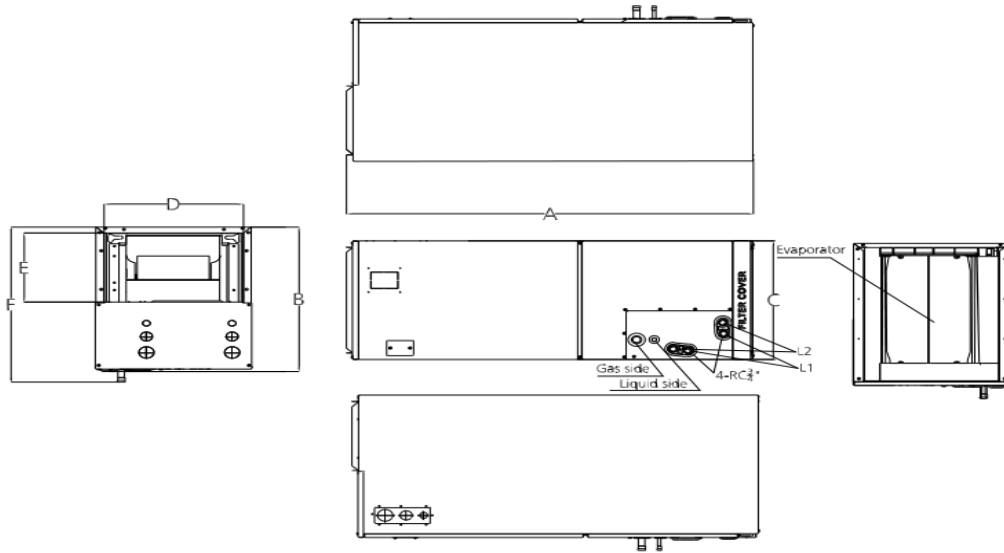

Model	Unit	Dimensions(mm)						Drain hole	
		A	B	C	D	E	F	L1	L2
18k~24k	mm	1143	534	445	400	260	585	Main drain	Overflow drain
	inch	45	21	17-1/2	15-3/4	10-1/4	23		
30k~48k	mm	1245	534	534	490	260	585		
	inch	49	21	21	19-5/16	10-1/4	23		
60k	mm	1346	534	622	580	260	585		
	inch	53	21	24-1/2	22-7/8	10-1/4	23		

Outdoor unit dimension

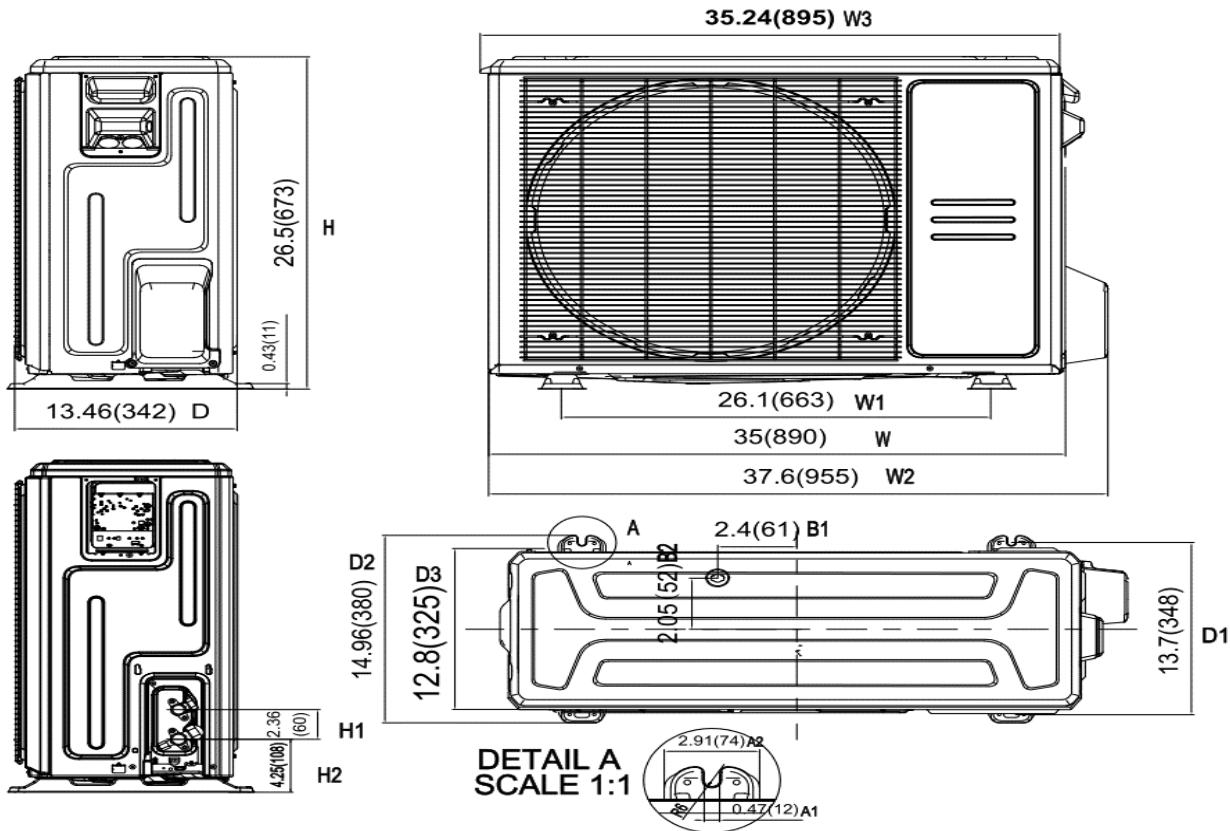

Fan performance

